

**COURSE NAME: OPERATING SYSTEMS**

**COURSE CODE: 21CS44**

**SEMESTER: 4**

**MODULE: 3**

**NUMBER OF HOURS: 8**

**CONTENTS:**

❖ **Deadlocks:**

- Deadlocks;
- System model;
- Deadlock characterization;
- Methods for handling deadlocks;
- Deadlock prevention;
- Deadlock avoidance;
- Deadlock detection and recovery from deadlock.

❖ **Memory Management:**

- Memory management strategies: Background;
- Swapping;
- Contiguous memory allocation;
- Paging;
- Structure of page table;
- Segmentation.

❖ **Question Bank:**

❖ **WEB RESOURCES:**

<https://www.geeksforgeeks.org/operating-systems/>

[https://www.tutorialspoint.com/operating\\_system/index.htm](https://www.tutorialspoint.com/operating_system/index.htm)

# MODULE 3

## DEADLOCKS

A process requests resources, if the resources are not available at that time, the process enters a waiting state. Sometimes, a waiting process is never again able to change state, because the resources it has requested are held by other waiting processes. This situation is called a **Deadlock**.

### SYSTEM MODEL

- A system consists of a finite number of resources to be distributed among a number of competing processes. The resources are partitioned into several types, each consisting of some number of identical instances. Memory space, CPU cycles, files, and I/O devices are examples of resource types.
- A process must request a resource before using it and must release the resource after using it. A process may request as many resources as it requires carrying out its designated task. The number of resources requested may not exceed the total number of resources available in the system.

Under the normal mode of operation, a process may utilize a resource in only the following sequence:

1. **Request:** The process requests the resource. If the request cannot be granted immediately, then the requesting process must wait until it can acquire the resource.
2. **Use:** The process can operate on the resource.
3. **Release:** The process releases the resource.

A set of processes is in a deadlocked state when every process in the set is waiting for an event that can be caused only by another process in the set. The events with which we are mainly concerned here are resource acquisition and release. The resources may be either physical resources or logical resources

To illustrate a deadlocked state, consider a system with three CD RW drives.

Suppose each of three processes holds one of these CD RW drives. If each process now requests another drive, the three processes will be in a deadlocked state.

Each is waiting for the event "CD RW is released," which can be caused only by one of the other waiting processes. This example illustrates a deadlock involving the same resource type.

Deadlocks may also involve different resource types. For example, consider a system with one printer and one DVD drive. Suppose that process  $P_i$  is holding the DVD and process  $P_j$  is holding the printer. If  $P_i$  requests the printer and  $P_j$  requests the DVD drive, a deadlock occurs.

## DEADLOCK CHARACTERIZATION

### Necessary Conditions

A deadlock situation can arise if the following four conditions hold simultaneously in a system:

1. **Mutual exclusion:** At least one resource must be held in a non-sharable mode, that is, only one process at a time can use the resource. If another process requests that resource, the requesting process must be delayed until the resource has been released.
2. **Hold and wait:** A process must be holding at least one resource and waiting to acquire additional resources that are currently being held by other processes.
3. **No preemption:** Resources cannot be preempted; that is, a resource can be released only voluntarily by the process holding it, after that process has completed its task.
4. **Circular wait:** A set  $\{P_0, P_1, \dots, P_n\}$  of waiting processes must exist such that  $P_0$  is waiting for a resource held by  $P_1$ ,  $P_1$  is waiting for a resource held by  $P_2$ ,  $\dots$ ,  $P_{n-1}$  is waiting for a resource held by  $P_n$  and  $P_n$  is waiting for a resource held by  $P_0$ .

### Resource-Allocation Graph

Deadlocks can be described in terms of a directed graph called **System Resource-Allocation Graph**

The graph consists of a set of vertices  $V$  and a set of edges  $E$ . The set of vertices  $V$  is partitioned into two different types of nodes:

- $P = \{P_1, P_2, \dots, P_n\}$ , the set consisting of all the active processes in the system.
- $R = \{R_1, R_2, \dots, R_m\}$  the set consisting of all resource types in the system.

A directed edge from process  $P_i$  to resource type  $R_j$  is denoted by  $P_i \rightarrow R_j$  it signifies that process  $P_i$  has requested an instance of resource type  $R_j$  and is currently waiting for that resource.

A directed edge from resource type  $R_j$  to process  $P_i$  is denoted by  $R_j \rightarrow P_i$  it signifies that an instance of resource type  $R_j$  has been allocated to process  $P_i$ .

- A directed edge  $P_i \rightarrow R_j$  is called a Request Edge.
- A directed edge  $R_j \rightarrow P_i$  is called an Assignment Edge.

Pictorially each process  $P_i$  as a circle and each resource type  $R_j$  as a rectangle. Since resource type  $R_j$  may have more than one instance, each instance is represented as a dot within the rectangle.

A request edge points to only the rectangle  $R_j$ , whereas an assignment edge must also designate one of the dots in the rectangle.

When process  $P_i$  requests an instance of resource type  $R_j$ , a request edge is inserted in the resource-allocation graph. When this request can be fulfilled, the request edge is *instantaneously* transformed to an assignment edge. When the process no longer needs access to the resource, it releases the resource; as a result, the assignment edge is deleted.

The resource-allocation graph shown in Figure depicts the following situation.

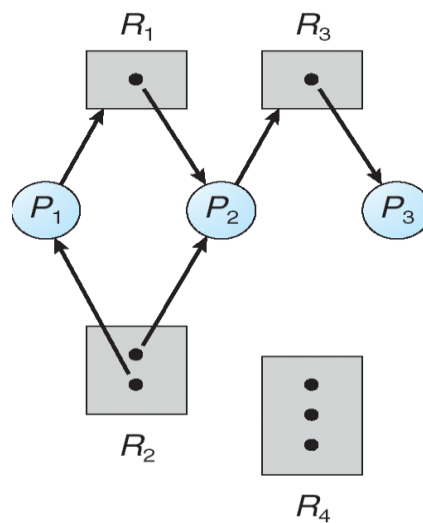

The sets  $P$ ,  $K$  and  $E$ :

- $P = \{P_1, P_2, P_3\}$
- $R = \{R_1, R_2, R_3, R_4\}$
- $E = \{P_1 \rightarrow R_1, P_2 \rightarrow R_3, R_1 \rightarrow P_2, R_2 \rightarrow P_2, R_2 \rightarrow P_1, R_3 \rightarrow P_3\}$

Resource instances:

- One instance of resource type  $R_1$
- Two instances of resource type  $R_2$
- One instance of resource type  $R_3$
- Three instances of resource type  $R_4$

Process states:

- Process  $P_1$  is holding an instance of resource type  $R_2$  and is waiting for an instance of resource type  $R_1$ .
- Process  $P_2$  is holding an instance of  $R_1$  and an instance of  $R_2$  and is waiting for an instance of  $R_3$ .
- Process  $P_3$  is holding an instance of  $R_3$ .

**If the graph does contain a cycle, then a deadlock may exist.**

- If each resource type has exactly **one instance**, then a cycle implies that a deadlock has occurred. If the cycle involves only a set of resource types, each of which has only a single instance, then a deadlock has occurred. Each process involved in the cycle is deadlocked.
- If each resource type has **several instances**, then a cycle does not necessarily imply that a deadlock has occurred. In this case, a cycle in the graph is a necessary but not a sufficient condition for the existence of deadlock.

To illustrate this concept, the resource-allocation graph depicted in below figure:

Suppose that process P3 requests an instance of resource type R2. Since no resource instance is currently available, a request edge  $P_3 \rightarrow R_2$  is added to the graph. At this point, two minimal cycles exist in the system:

1.  $P_1 \rightarrow R_1 \rightarrow P_2 \rightarrow R_3 \rightarrow P_3 \rightarrow R_2 \rightarrow P_1$
2.  $P_2 \rightarrow R_3 \rightarrow P_3 \rightarrow R_2 \rightarrow P_2$

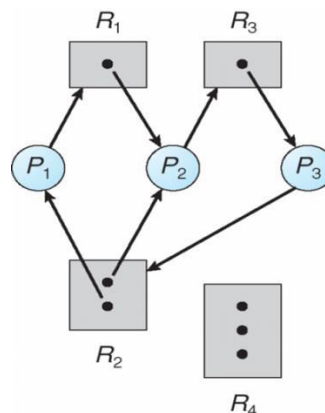

Figure: Resource-allocation graph with a deadlock.

Processes P1, P2, and P3 are deadlocked. Process P2 is waiting for the resource R3, which is held by process P3. Process P3 is waiting for either process P1 or process P2 to release resource R2. In addition, process P1 is waiting for process P2 to release resource R1.

Consider the resource-allocation graph in below Figure. In this example also have a cycle:

$$P_1 \rightarrow R_1 \rightarrow P_3 \rightarrow R_2 \rightarrow P_1$$

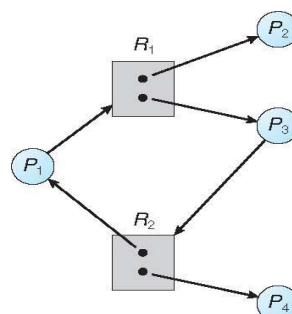

Figure: Resource-allocation graph with a cycle but no deadlock

However, there is no deadlock. Observe that process P4 may release its instance of resource type R2. That resource can then be allocated to P3, breaking the cycle.

## **METHODS FOR HANDLING DEADLOCKS**

The deadlock problem can be handled in one of three ways:

1. Use a protocol to prevent or avoid deadlocks, ensuring that the system will never enter a deadlocked state.
2. Allow the system to enter a deadlocked state, detect it, and recover.
3. Ignore the problem altogether and pretend that deadlocks never occur in the system.

To ensure that deadlocks never occur, the system can use either deadlock prevention or a deadlock-avoidance scheme.

**Deadlock prevention** provides a set of methods for ensuring that at least one of the necessary conditions cannot hold. These methods prevent deadlocks by constraining how requests for resources can be made.

**Deadlock-avoidance** requires that the operating system be given in advance additional information concerning which resources a process will request and use during its lifetime. With this additional knowledge, it can decide for each request whether or not the process should wait. To decide whether the current request can be satisfied or must be delayed, the system must consider the resources currently available, the resources currently allocated to each process, and the future requests and releases of each process

If a system does not employ either a deadlock-prevention or a deadlock avoidance algorithm, then a deadlock situation may arise. In this environment, the system can provide an **algorithm** that examines the state of the system to determine whether a deadlock has occurred and an algorithm to recover from the deadlock.

In the absence of algorithms to detect and recover from deadlocks, then the system is in a deadlock state yet has no way of recognizing what has happened. In this case, the undetected deadlock will result in deterioration of the system's performance, because resources are being held by processes that cannot run and because more and more processes, as they make requests for resources, will enter a deadlocked state. Eventually, the system will stop functioning and will need to be restarted manually.

## **DEADLOCK PREVENTION**

Deadlock can be prevented by ensuring that at least one of the four necessary conditions cannot hold.

### **Mutual Exclusion**

- The mutual-exclusion condition must hold for non-sharable resources. Sharable resources, do not require mutually exclusive access and thus cannot be involved in a deadlock.
- Ex: Read-only files are example of a sharable resource. If several processes attempt to open a read-only file at the same time, they can be granted simultaneous access to the file. A process never needs to wait for a sharable resource.
- Deadlocks cannot prevent by denying the mutual-exclusion condition, because some resources are intrinsically non-sharable.

### **Hold and Wait**

To ensure that the hold-and-wait condition never occurs in the system, then guarantee that, whenever a process requests a resource, it does not hold any other resources.

- One protocol that can be used requires each process to request and be allocated all its resources before it begins execution.
- Another protocol allows a process to request resources only when it has none. A process may request some resources and use them. Before it can request any additional resources, it must release all the resources that it is currently allocated.

Ex:

- Consider a process that copies data from a DVD drive to a file on disk, sorts the file, and then prints the results to a printer. If all resources must be requested at the beginning of the process, then the process must initially request the DVD drive, disk file, and printer. It will hold the printer for its entire execution, even though it needs the printer only at the end.
- The second method allows the process to request initially only the DVD drive and disk file. It copies from the DVD drive to the disk and then releases both the DVD drive and the disk file. The process must then again request the disk file and the printer. After copying the disk file to the printer, it releases these two resources and terminates.

### **The two main disadvantages of these protocols:**

1. Resource utilization may be low, since resources may be allocated but unused for a long period.
2. Starvation is possible.

## **No Preemption**

The third necessary condition for deadlocks is that there be no preemption of resources that have already been allocated.

To ensure that this condition does not hold, the following protocols can be used:

- If a process is holding some resources and requests another resource that cannot be immediately allocated to it, then all resources the process is currently holding are preempted.
- The preempted resources are added to the list of resources for which the process is waiting. The process will be restarted only when it can regain its old resources, as well as the new ones that it is requesting.

If a process requests some resources, first check whether they are available. If they are, allocate them.

If they are not available, check whether they are allocated to some other process that is waiting for additional resources. If so, preempt the desired resources from the waiting process and allocate them to the requesting process.

If the resources are neither available nor held by a waiting process, the requesting process must wait. While it is waiting, some of its resources may be preempted, but only if another process requests them.

A process can be restarted only when it is allocated the new resources it is requesting and recovers any resources that were preempted while it was waiting.

## **Circular Wait**

One way to ensure that this condition never holds is to impose a total ordering of all resource types and to require that each process requests resources in an increasing order of enumeration.

To illustrate, let  $R = \{R_1, R_2, \dots, R_m\}$  be the set of resource types. Assign a unique integer number to each resource type, which allows to compare two resources and to determine whether one precedes another in ordering. Formally, it defined as a one-to-one function

$F: R \rightarrow \mathbb{N}$ , where  $\mathbb{N}$  is the set of natural numbers.

Example: if the set of resource types  $R$  includes tape drives, disk drives, and printers, then the function  $F$  might be defined as follows:

$$F(\text{tape drive}) = 1$$

$$F(\text{disk drive}) = 5$$

$$F(\text{printer}) = 12$$

Now consider the following protocol to prevent deadlocks. Each process can request resources only in an increasing order of enumeration. That is, a process can initially request any number of instances of a resource type  $R_i$ . After that, the process can request instances of resource type  $R_j$  if and only if  $F(R_j) > F(R_i)$ .



## DEADLOCK AVOIDANCE

- To avoid deadlocks an additional information is required about how resources are to be requested. With the knowledge of the complete sequence of requests and releases for each process, the system can decide for each request whether or not the process should wait in order to avoid a possible future deadlock
- Each request requires that in making this decision the system consider the resources currently available, the resources currently allocated to each process, and the future requests and releases of each process.
- The various algorithms that use this approach differ in the amount and type of information required. The simplest model requires that each process declare the *maximum number* of resources of each type that it may need. Given this a priori information, it is possible to construct an algorithm that ensures that the system will never enter a deadlocked state. Such an algorithm defines the *deadlock-avoidance approach*.

### Safe State

- **Safe state:** A state is safe if the system can allocate resources to each process (up to its maximum) in some order and still avoid a deadlock. A system is in a safe state only if there exists a safe sequence.
- **Safe sequence:** A sequence of processes  $\langle P_1, P_2, \dots, P_n \rangle$  is a safe sequence for the current allocation state if, for each  $P_i$ , the resource requests that  $P_i$  can still make can be satisfied by the currently available resources plus the resources held by all  $P_j$ , with  $j < i$ .

In this situation, if the resources that  $P_i$  needs are not immediately available, then  $P_i$  can wait until all  $P_j$  have finished. When they have finished,  $P_i$  can obtain all of its needed resources, complete its designated task, return its allocated resources, and terminate. When  $P_i$  terminates,  $P_{i+1}$  can obtain its needed resources, and so on. If no such sequence exists, then the system state is said to be unsafe.

A safe state is not a deadlocked state. Conversely, a deadlocked state is an unsafe state. Not all unsafe states are deadlocks as shown in figure. An unsafe state may lead to a deadlock. As long as the state is safe, the operating system can avoid unsafe states

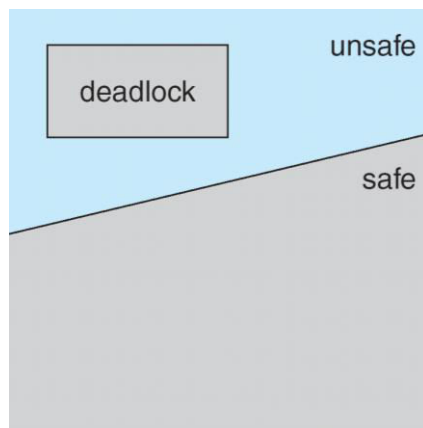

**Figure:** Safe, unsafe, and deadlocked state spaces.

### Resource-Allocation-Graph Algorithm

- If a resource-allocation system has only one instance of each resource type, then a variant of the resource-allocation graph is used for deadlock avoidance.
- In addition to the request and assignment edges, a new type of edge is introduced, called a claim edge.
- A claim edge  $P_i \rightarrow R_j$  indicates that process  $P_i$  may request resource  $R_j$  at some time in the future. This edge resembles a request edge in direction but is represented in the graph by a **dashed line**.
- When process  $P_i$  requests resource  $R_j$ , the claim edge  $P_i \rightarrow R_j$  is converted to a request edge. When a resource  $R_j$  is released by  $P_i$  the assignment edge  $R_j \rightarrow P_i$  is reconverted to a claim edge  $P_i \rightarrow R_j$ .

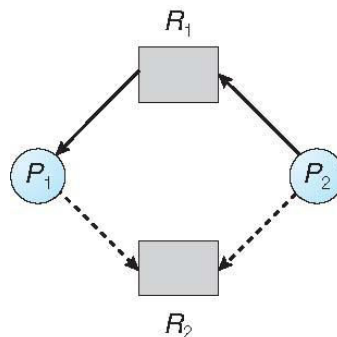

**Figure:** Resource-allocation graph for deadlock avoidance.

Note that the resources must be claimed a priori in the system. That is, before process  $P_i$  starts executing, all its claim edges must already appear in the resource-allocation graph.

We can relax this condition by allowing a claim edge  $P_i \rightarrow R_j$  to be added to the graph only if all the edges associated with process  $P_i$  are claim edges.

Now suppose that process  $P_i$  requests resource  $R_j$ . The request can be granted only if converting the request edge  $P_i \rightarrow R_j$  to an assignment edge  $R_j \rightarrow P_i$  does not result in the formation of a cycle in the resource-allocation graph.

There is need to check for safety by using a cycle-detection algorithm. An algorithm for detecting a cycle in this graph requires an order of  $n^2$  operations, where  $n$  is the number of processes in the system.

- If no cycle exists, then the allocation of the resource will leave the system in a safe state.
- If a cycle is found, then the allocation will put the system in an unsafe state. In that case, process  $P_i$  will have to wait for its requests to be satisfied.

To illustrate this algorithm, consider the resource-allocation graph as shown above. Suppose that  $P_2$  requests  $R_2$ . Although  $R_2$  is currently free, we cannot allocate it to  $P_2$ , since this action will create a cycle in the graph.

A cycle, indicates that the system is in an unsafe state. If  $P_1$  requests  $R_2$ , and  $P_2$  requests  $R_1$ , then a deadlock will occur.

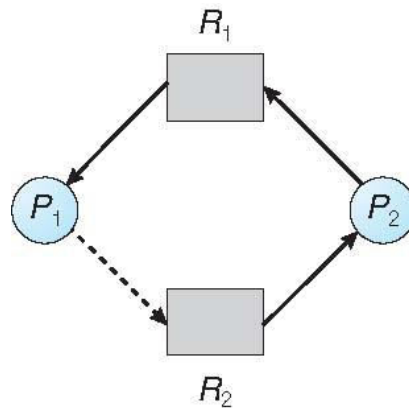

**Figure:** An unsafe state in a resource-allocation graph

## **Banker's Algorithm**

The Banker's algorithm is applicable to a resource allocation system with multiple instances of each resource type.

- When a new process enters the system, it must declare the maximum number of instances of each resource type that it may need. This number may not exceed the total number of resources in the system.
- When a user requests a set of resources, the system must determine whether the allocation of these resources will leave the system in a safe state. If it will, the resources are allocated; otherwise, the process must wait until some other process releases enough resources.

To implement the banker's algorithm the following data structures are used.

Let  $n$  = number of processes, and  $m$  = number of resources types

**Available:** A vector of length  $m$  indicates the number of available resources of each type. If  $\text{Available}[j] = k$ , there are  $k$  instances of resource type  $R_j$  available.

**Max:** An  $n \times m$  matrix defines the maximum demand of each process. If  $\text{Max}[i,j] = k$ , then process  $P_i$  may request at most  $k$  instances of resource type  $R_j$

**Allocation:** An  $n \times m$  matrix defines the number of resources of each type currently allocated to each process. If  $\text{Allocation}[i,j] = k$  then  $P_i$  is currently allocated  $k$  instances of  $R_j$

**Need:** An  $n \times m$  matrix indicates the remaining resource need of each process. If  $\text{Need}[i,j] = k$ , then  $P_i$  may need  $k$  more instances of  $R_j$  to complete its task.

$$\text{Need}[i,j] = \text{Max}[i,j] - \text{Allocation}[i,j]$$

### Safety Algorithm

The algorithm for finding out whether or not a system is in a safe state. This algorithm can be described as follows:

1. Let **Work** and **Finish** be vectors of length  $m$  and  $n$ , respectively. Initialize:

**Work** = **Available**

**Finish**  $[i] = \text{false}$  for  $i = 0, 1, \dots, n-1$

2. Find an index  $i$  such that both:

(a) **Finish** $[i] = \text{false}$

(b)  $\text{Need}_i \leq \text{Work}$

If no such  $i$  exists, go to step 4

3. **Work** = **Work** + **Allocation** $_i$

**Finish** $[i] = \text{true}$

go to step 2

4. If **Finish**  $[i] == \text{true}$  for all  $i$ , then the system is in a safe state

This algorithm may require an order of  $m \times n^2$  operations to determine whether a state is safe.

## Resource-Request Algorithm

The algorithm for determining whether requests can be safely granted.

Let  $Request_i$  be the request vector for process  $P_i$ . If  $Request_i[j] = k$ , then process  $P_i$  wants  $k$  instances of resource type  $R_j$ . When a request for resources is made by process  $P_i$ , the following actions are taken:

1. If  $Request_i \leq Need_i$  go to step 2. Otherwise, raise error condition, since process has exceeded its maximum claim
2. If  $Request_i \leq Available$ , go to step 3. Otherwise  $P_i$  must wait, since resources are not available
3. Have the system pretend to allocate requested resources to  $P_i$  by modifying the state as follows:

$$Available = Available - Request_i;$$

$$Allocation_i = Allocation_i + Request_i;$$

$$Need_i = Need_i - Request_i;$$

If safe  $\Rightarrow$  the resources are allocated to  $P_i$

If unsafe  $\Rightarrow P_i$  must wait, and the old resource-allocation state is restored

### Example

Consider a system with five processes  $P_0$  through  $P_4$  and three resource types  $A$ ,  $B$ , and  $C$ . Resource type  $A$  has ten instances, resource type  $B$  has five instances, and resource type  $C$  has seven instances. Suppose that, at time  $T_0$  the following snapshot of the system has been taken:

	<u>Allocation</u>	<u>Max</u>	<u>Available</u>
	A B C	A B C	A B C
$P_0$	0 1 0	7 5 3	3 3 2
$P_1$	2 0 0	3 2 2	
$P_2$	3 0 2	9 0 2	
$P_3$	2 1 1	2 2 2	
$P_4$	0 0 2	4 3 3	

The content of the matrix *Need* is defined to be *Max - Allocation*

	<u>Need</u>		
	A	B	C
$P_0$	7	4	3
$P_1$	1	2	2
$P_2$	6	0	0
$P_3$	0	1	1
$P_4$	4	3	1

The system is currently in a safe state. Indeed, the sequence  $\langle P_1, P_3, P_4, P_2, P_0 \rangle$  satisfies the safety criteria.

Suppose now that process  $P_1$  requests one additional instance of resource type A and two instances of resource type C, so  $\text{Request}_1 = (1,0,2)$ . Decide whether this request can be immediately granted.

Check that  $\text{Request} \leq \text{Available}$

$$(1,0,2) \leq (3,3,2) \Rightarrow \text{true}$$

Then pretend that this request has been fulfilled, and the following new state is arrived.

	<u>Allocation</u>			<u>Need</u>			<u>Available</u>		
	A	B	C	A	B	C	A	B	C
$P_0$	0	1	0	7	4	3	2	3	0
$P_1$	3	0	2	0	2	0			
$P_2$	3	0	2	6	0	0			
$P_3$	2	1	1	0	1	1			
$P_4$	0	0	2	4	3	1			

Executing safety algorithm shows that sequence  $\langle P_1, P_3, P_4, P_0, P_2 \rangle$  satisfies safety requirement.

## DEADLOCK DETECTION

If a system does not employ either a deadlock-prevention or a deadlock avoidance algorithm, then a deadlock situation may occur. In this environment, the system may provide:

- An algorithm that examines the state of the system to determine whether a deadlock has occurred
- An algorithm to recover from the deadlock

### Single Instance of Each Resource Type

- If all resources have only a single instance, then define a deadlock detection algorithm that uses a variant of the resource-allocation graph, called a *wait-for* graph.
- This graph is obtained from the resource-allocation graph by removing the resource nodes and collapsing the appropriate edges.
- An edge from  $P_i$  to  $P_j$  in a wait-for graph implies that process  $P_i$  is waiting for process  $P_j$  to release a resource that  $P_i$  needs. An edge  $P_i \rightarrow P_j$  exists in a wait-for graph if and only if the corresponding resource allocation graph contains two edges  $P_i \rightarrow R_q$  and  $R_q \rightarrow P_j$  for some resource  $R_q$ .

Example: In below Figure, a resource-allocation graph and the corresponding wait-for graph is presented.

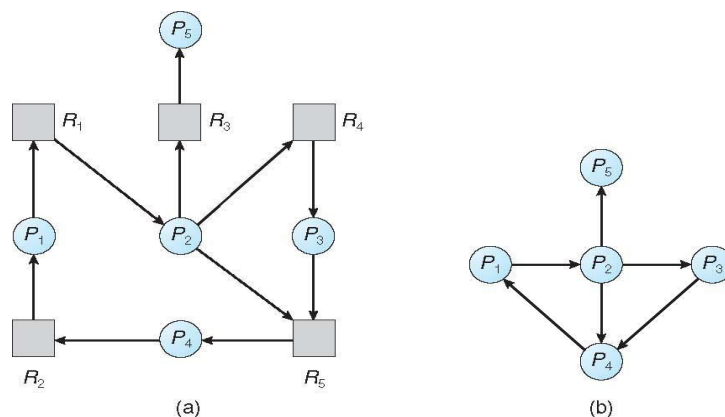

Figure: (a) Resource-allocation graph. (b) Corresponding wait-for graph.

- A deadlock exists in the system if and only if the wait-for graph contains a cycle. To detect deadlocks, the system needs to *maintain* the wait-for graph and periodically *invoke an algorithm* that searches for a cycle in the graph.
- An algorithm to detect a cycle in a graph requires an order of  $n^2$  operations, where  $n$  is the number of vertices in the graph.

## Several Instances of a Resource Type

A deadlock detection algorithm that is applicable to several instances of a resource type. The algorithm employs several time-varying data structures that are similar to those used in the banker's algorithm.

- **Available:** A vector of length  $m$  indicates the number of available resources of each type.
- **Allocation:** An  $n \times m$  matrix defines the number of resources of each type currently allocated to each process.
- **Request:** An  $n \times m$  matrix indicates the current request of each process. If  $Request[i][j]$  equals  $k$ , then process  $P_i$  is requesting  $k$  more instances of resource type  $R_j$ .

### Algorithm:

1. Let  $Work$  and  $Finish$  be vectors of length  $m$  and  $n$ , respectively Initialize:
  - (a)  $Work = Available$
  - (b) For  $i = 1, 2, \dots, n$ , if  $Allocation_i \neq 0$ , then  $Finish[i] = false$ ; otherwise,  $Finish[i] = true$
2. Find an index  $i$  such that both:
  - (a)  $Finish[i] == false$
  - (b)  $Request_i \leq Work$

If no such  $i$  exists, go to step 4

3.  $Work = Work + Allocation_i$   
 $Finish[i] = true$   
go to step 2

4. If  $Finish[i] == false$ , for some  $i$ ,  $1 \leq i \leq n$ , then the system is in deadlock state. Moreover, if  $Finish[i] == false$ , then  $P_i$  is deadlocked

**Algorithm requires an order of  $O(m \times n^2)$  operations to detect whether the system is in deadlocked state**

### Example of Detection Algorithm

Consider a system with five processes  $P_0$  through  $P_4$  and three resource types  $A$ ,  $B$ , and  $C$ . Resource type  $A$  has seven instances, resource type  $B$  has two instances, and resource type  $C$  has six instances. Suppose that, at time  $T_0$ , the following resource-allocation state:



	<u>Allocation</u>	<u>Request</u>	<u>Available</u>
	A B C	A B C	A B C
$P_0$	0 1 0	0 0 0	0 0 0
$P_1$	2 0 0	2 0 2	
$P_2$	3 0 3	0 0 0	
$P_3$	2 1 1	1 0 0	
$P_4$	0 0 2	0 0 2	

After executing the algorithm, Sequence  $\langle P_0, P_2, P_3, P_1, P_4 \rangle$  will result in  $Finish[i] = true$  for all  $i$

Suppose now that process  $P_2$  makes one additional request for an instance of type C. The Request matrix is modified as follows:

	<u>Request</u>
	A B C
$P_0$	0 0 0
$P_1$	2 0 2
$P_2$	0 0 1
$P_3$	1 0 0
$P_4$	0 0 2

The system is now deadlocked. Although we can reclaim the resources held by process  $P_0$ , the number of available resources is not sufficient to fulfill the requests of the other processes. Thus, a deadlock exists, consisting of processes  $P_1, P_2, P_3,$  and  $P_4$ .

### Detection-Algorithm Usage

The detection algorithm can be invoked on two factors:

1. How *often* is a deadlock likely to occur?
2. How *many* processes will be affected by deadlock when it happens?

If deadlocks occur frequently, then the detection algorithm should be invoked frequently. Resources allocated to deadlocked processes will be idle until the deadlock can be broken.

If detection algorithm is invoked arbitrarily, there may be many cycles in the resource graph and so we would not be able to tell which of the many deadlocked processes “caused” the deadlock.

## RECOVERY FROM DEADLOCK

The system recovers from the deadlock automatically. There are two options for breaking a deadlock one is simply to abort one or more processes to break the circular wait. The other is to preempt some resources from one or more of the deadlocked processes.

### Process Termination

To eliminate deadlocks by aborting a process, use one of two methods. In both methods, the system reclaims all resources allocated to the terminated processes.

1. **Abort all deadlocked processes:** This method clearly will break the deadlock cycle, but at great expense; the deadlocked processes may have computed for a long time, and the results of these partial computations must be discarded and probably will have to be recomputed later.
2. **Abort one process at a time until the deadlock cycle is eliminated:** This method incurs considerable overhead, since after each process is aborted, a deadlock-detection algorithm must be invoked to determine whether any processes are still deadlocked.

If the partial termination method is used, then we must determine which deadlocked process (or processes) should be terminated. Many factors may affect which process is chosen, including:

1. What the priority of the process is
2. How long the process has computed and how much longer the process will compute before completing its designated task
3. How many and what types of resources the process has used.
4. How many more resources the process needs in order to complete
5. How many processes will need to be terminated?
6. Whether the process is interactive or batch

### Resource Preemption

To eliminate deadlocks using resource preemption, we successively preempt some resources from processes and give these resources to other processes until the deadlock cycle is broken.

If preemption is required to deal with deadlocks, then three issues need to be addressed:

1. **Selecting a victim.** Which resources and which processes are to be preempted? As in process termination, we must determine the order of preemption to minimize cost. Cost factors may include such parameters as the number of resources a deadlocked process is holding and the amount of time the process has thus far consumed during its execution.
2. **Rollback.** If we preempt a resource from a process, what should be done with that process? Clearly, it cannot continue with its normal execution; it is missing some needed resource. We must roll back the process to some safe state and restart it from that state. Since it is difficult to determine what a safe state is, the simplest solution is a total rollback: abort the process and then restart it.

- 
3. **Starvation.** How do we ensure that starvation will not occur? That is, how can we guarantee that resources will not always be preempted from the same process?

# MEMORY MANAGEMENT

## Main Memory Management Strategies

- Every program to be executed has to be executed must be in memory. The instruction must be fetched from memory before it is executed.
- In multi-tasking OS memory management is complex, because as processes are swapped in and out of the CPU, their code and data must be swapped in and out of memory.

## Basic Hardware

- Main memory, cache and CPU registers in the processors are the only storage spaces that CPU can access directly.
- The program and data must be bought into the memory from the disk, for the process to run. Each process has a separate memory space and must access only this range of legal addresses. Protection of memory is required to ensure correct operation. This prevention is provided by hardware implementation.
- Two registers are used - a base register and a limit register. The base register holds the smallest legal physical memory address; the limit register specifies the size of the range.
- For example, The base register holds the smallest legal physical memory address; the limit register specifies the size of the range. For example, if the base register holds 300040 and limit register is 120900, then the program can legally access all addresses from 300040 through 420940 (inclusive).

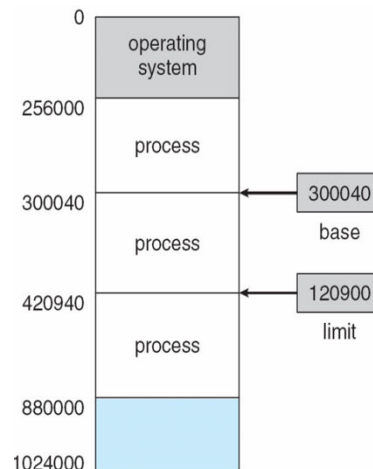

Figure: A base and a limit-register define a logical-address space

- The base and limit registers can be loaded only by the operating system, which uses a special privileged instruction. Since privileged instructions can be executed only in kernel mode only the operating system can load the base and limit registers.

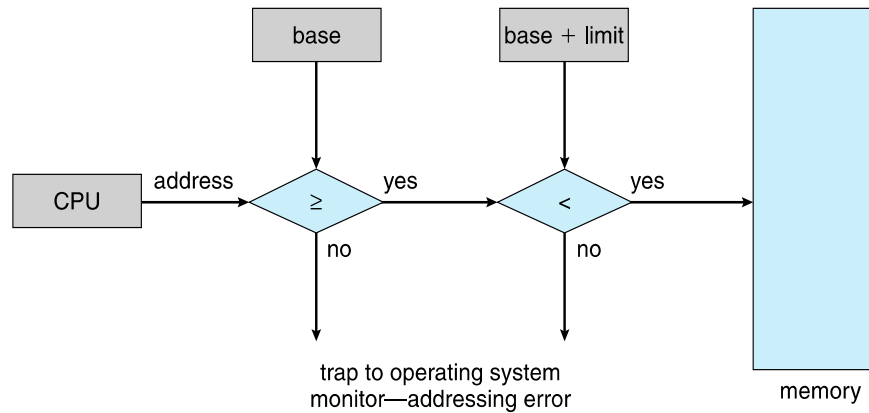

Figure: Hardware address protection with base and limit-registers

### Address Binding

- User programs typically refer to memory addresses with symbolic names. These symbolic names must be mapped or bound to physical memory addresses.
- Address binding of instructions to memory-addresses can happen at 3 different stages.
  1. **Compile Time** - If it is known at compile time where a program will reside in physical memory, then absolute code can be generated by the compiler, containing actual physical addresses. However, if the load address changes at some later time, then the program will have to be recompiled.
  2. **Load Time** - If the location at which a program will be loaded is not known at compile time, then the compiler must generate relocatable code, which references addresses relative to the start of the program. If that starting address changes, then the program must be reloaded but not recompiled.
  3. **Execution Time** - If a program can be moved around in memory during the course of its execution, then binding must be delayed until execution time.

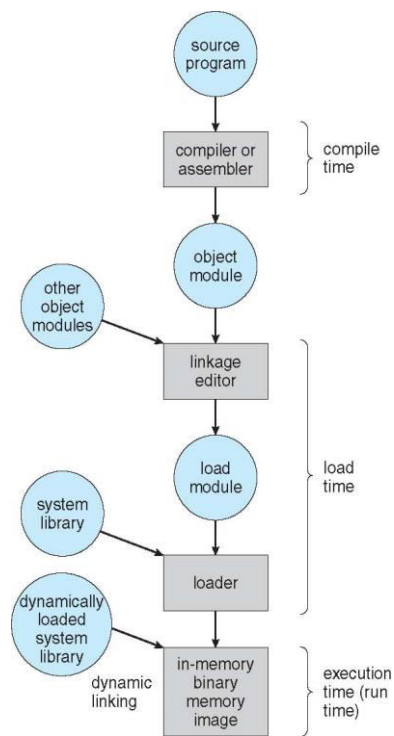

Figure: Multistep processing of a user program

### Logical Versus Physical Address Space

- The address generated by the CPU is a logical address, whereas the memory address where programs are actually stored is a physical address.
- The set of all logical addresses used by a program composes the logical address space, and the set of all corresponding physical addresses composes the physical address space.
- The run time mapping of logical to physical addresses is handled by the memory-management unit (MMU).
  - One of the simplest is a modification of the base-register scheme.
  - The base register is termed a relocation register
  - The value in the relocation-register is added to every address generated by a user-process at the time it is sent to memory.
  - The user-program deals with logical-addresses; it never sees the real physical-addresses.

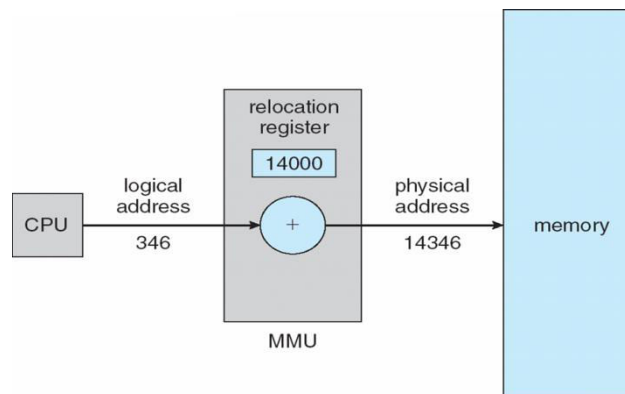

Figure: Dynamic relocation using a relocation-register

## Dynamic Loading

- This can be used to obtain better memory-space utilization.
- A routine is not loaded until it is called.

This works as follows:

1. Initially, all routines are kept on disk in a relocatable-load format.
2. Firstly, the main-program is loaded into memory and is executed.
3. When a main-program calls the routine, the main-program first checks to see whether the routine has been loaded.
4. If routine has been not yet loaded, the loader is called to load desired routine into memory.
5. Finally, control is passed to the newly loaded-routine.

Advantages:

1. An unused routine is never loaded.
2. Useful when large amounts of code are needed to handle infrequently occurring cases.
3. Although the total program-size may be large, the portion that is used (and hence loaded) may be much smaller.
4. Does not require special support from the OS.

## Dynamic Linking and Shared Libraries

- With **static linking** library modules get fully included in executable modules, wasting both disk space and main memory usage, because every program that included a certain routine from the library would have to have their own copy of that routine linked into their executable code.
- With **dynamic linking**, however, only a stub is linked into the executable module, containing references to the actual library module linked in at run time.
  - The stub is a small piece of code used to locate the appropriate memory-resident library-routine.
  - This method saves disk space, because the library routines do not need to be fully included in the executable modules, only the stubs.
  - An added benefit of dynamically linked libraries (DLLs, also known as shared libraries or shared objects on UNIX systems) involves easy upgrades and updates.

### **Shared libraries**

- A library may be replaced by a new version, and all programs that reference the library will automatically use the new one.
- Version info. is included in both program & library so that programs won't accidentally execute incompatible versions.

## Swapping

- A process must be loaded into memory in order to execute.
- If there is not enough memory available to keep all running processes in memory at the same time, then some processes that are not currently using the CPU may have their memory swapped out to a fast local disk called the *backing store*.
- *Swapping is the process of moving a process from memory to backing store and moving another process from backing store to memory.* Swapping is a very slow process compared to other operations.
- A variant of swapping policy is used for priority-based scheduling algorithms. If a higher-priority process arrives and wants service, the memory manager can swap out the lower-priority process and then load and execute the higher-priority process. When the higher-priority process finishes, the lower-priority process can be swapped back in and continued. This variant of swapping is *called roll out, roll in*.

Swapping depends upon address-binding:

- If binding is done at load-time, then process cannot be easily moved to a different location.
- If binding is done at execution-time, then a process can be swapped into a different memory-space, because the physical-addresses are computed during execution-time.

Major part of swap-time is transfer-time; i.e. total transfer-time is directly proportional to the amount of memory swapped.

Disadvantages:

1. Context-switch time is fairly high.
2. If we want to swap a process, we must be sure that it is completely idle.

Two solutions:

- i) Never swap a process with pending I/O.
- ii) Execute I/O operations only into OS buffers.

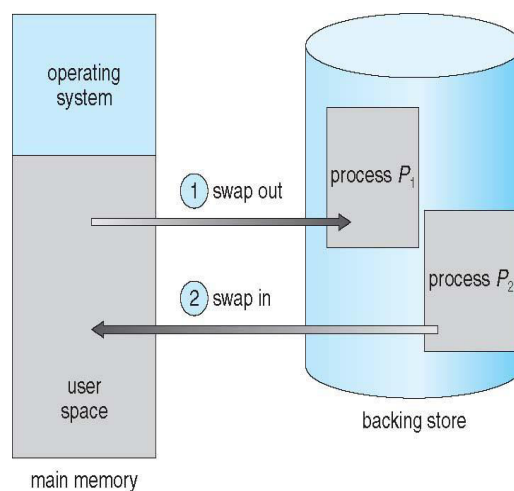

Figure: Swapping of two processes using a disk as a backing store



### **Example:**

Assume that the user process is 10 MB in size and the backing store is a standard hard disk with a transfer rate of 40 MB per second.

The actual transfer of the 10-MB process to or from main memory takes

$$\begin{aligned} 10000 \text{ KB}/40000 \text{ KB per second} &= 1/4 \text{ second} \\ &= 250 \text{ milliseconds.} \end{aligned}$$

Assuming that no head seeks are necessary, and assuming an average latency of 8 milliseconds, the swap time is 258 milliseconds. Since we must both swap out and swap in, the total swap time is about 516 milliseconds.

## **Contiguous Memory Allocation**

- The main memory must accommodate both the operating system and the various user processes. Therefore we need to allocate the parts of the main memory in the most efficient way possible.
- Memory is usually divided into 2 partitions: One for the resident OS. One for the user processes.
- Each process is contained in a single contiguous section of memory.

### **1. Memory Mapping and Protection**

- Memory-protection means protecting OS from user-process and protecting user-processes from one another.
- Memory-protection is done using
  - Relocation-register: contains the value of the smallest physical-address.
  - Limit-register: contains the range of logical-addresses.
- Each logical-address must be less than the limit-register.
- The MMU maps the logical-address dynamically by adding the value in the relocation-register. This mapped-address is sent to memory
- When the CPU scheduler selects a process for execution, the dispatcher loads the relocation and limit-registers with the correct values.
- Because every address generated by the CPU is checked against these registers, we can protect the OS from the running-process.
- The relocation-register scheme provides an effective way to allow the OS size to change dynamically.
- Transient OS code: Code that comes & goes as needed to save memory-space and overhead for unnecessary swapping.

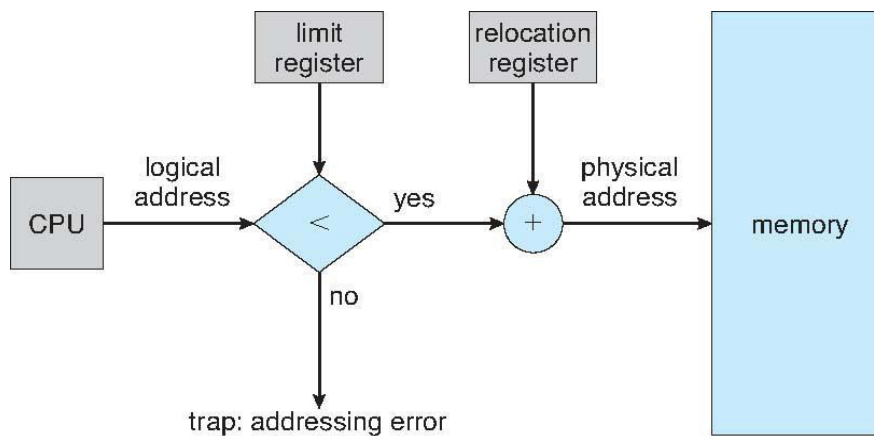

Figure: Hardware support for relocation and limit-registers

## 2. Memory Allocation

Two types of memory partitioning are:

1. Fixed-sized partitioning
2. Variable-sized partitioning

### 1. Fixed-sized Partitioning

- The memory is divided into fixed-sized partitions.
- Each partition may contain exactly one process.
- The degree of multiprogramming is bound by the number of partitions.
- When a partition is free, a process is selected from the input queue and loaded into the free partition.
- When the process terminates, the partition becomes available for another process.

### 2. Variable-sized Partitioning

- The OS keeps a table indicating which parts of memory are available and which parts are occupied.
- A hole is a block of available memory. Normally, memory contains a set of holes of various sizes.
- Initially, all memory is available for user-processes and considered one large hole.
- When a process arrives, the process is allocated memory from a large hole.
- If we find the hole, we allocate only as much memory as is needed and keep the remaining memory available to satisfy future requests.

### Three strategies used to select a free hole from the set of available holes:

1. First Fit: Allocate the first hole that is big enough. Searching can start either at the beginning of the set of holes or at the location where the previous first-fit search ended.
2. Best Fit: Allocate the smallest hole that is big enough. We must search the entire list, unless the list is ordered by size. This strategy produces the smallest leftover hole.
3. Worst Fit: Allocate the largest hole. Again, we must search the entire list, unless it is sorted by size. This strategy produces the largest leftover hole.

First-fit and best fit are better than worst fit in terms of decreasing time and storage utilization.

### 3. Fragmentation

Two types of memory fragmentation:

1. Internal fragmentation
2. External fragmentation

#### 1. Internal Fragmentation

- The general approach is to break the physical-memory into fixed-sized blocks and allocate memory in units based on block size.
- The allocated-memory to a process may be slightly larger than the requested-memory.
- The difference between requested-memory and allocated-memory is called internal fragmentation i.e. Unused memory that is internal to a partition.

#### 2. External Fragmentation

- External fragmentation occurs when there is enough total memory-space to satisfy a request but the available-spaces are not contiguous. (i.e. storage is fragmented into a large number of small holes).
- Both the first-fit and best-fit strategies for memory-allocation suffer from external fragmentation.
- Statistical analysis of first-fit reveals that given  $N$  allocated blocks, another  $0.5 N$  blocks will be lost to fragmentation. This property is known as the 50-percent rule.

Two solutions to external fragmentation:

- Compaction: The goal is to shuffle the memory-contents to place all free memory together in one large hole. Compaction is possible only if relocation is dynamic and done at execution-time
- Permit the logical-address space of the processes to be non-contiguous. This allows a process to be allocated physical-memory wherever such memory is available. Two techniques achieve this solution: 1) Paging and 2) Segmentation.

## Paging

- Paging is a memory-management scheme.
- This permits the physical-address space of a process to be non-contiguous.
- This also solves the considerable problem of fitting memory-chunks of varying sizes onto the backing-store.
- Traditionally: Support for paging has been handled by hardware.
- Recent designs: The hardware & OS are closely integrated.

### Basic Method of Paging

- The basic method for implementing paging involves breaking physical memory into fixed-sized blocks called frames and breaking logical memory into blocks of the same size called pages.
- When a process is to be executed, its pages are loaded into any available memory frames from the backing store.
- The backing store is divided into fixed-sized blocks that are of the same size as the memory frames.

The hardware support for paging is illustrated in Figure 1.

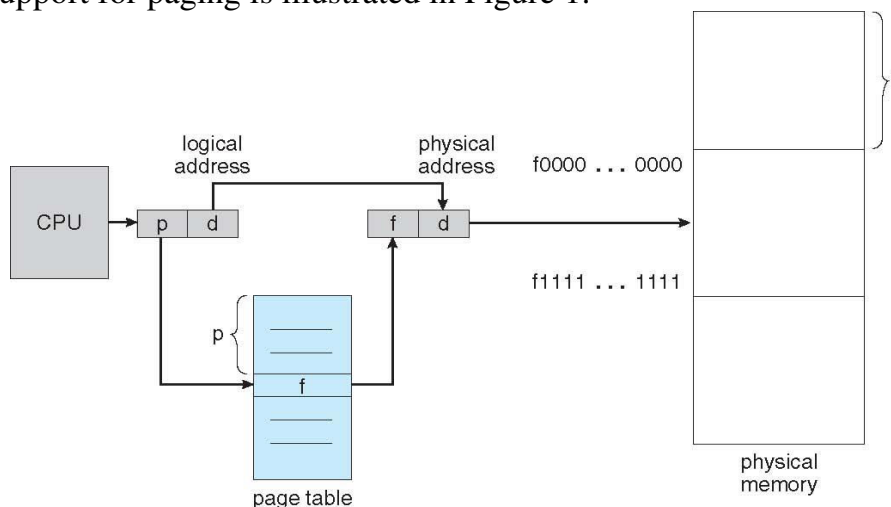

Figure 1: Paging hardware

- Address generated by CPU is divided into 2 parts (Figure 2):
  1. Page-number (p) is used as an index to the page-table. The page-table contains the base-address of each page in physical-memory.
  2. Offset (d) is combined with the base-address to define the physical-address. This physical-address is sent to the memory-unit.
- The page table maps the page number to a frame number, to yield a physical address
- The page table maps the page number to a frame number, to yield a physical address which also has two parts: The frame number and the offset within that frame.
- The number of bits in the frame number determines how many frames the system can address, and the number of bits in the offset determines the size of each frame.

The paging model of memory is shown in Figure 2.

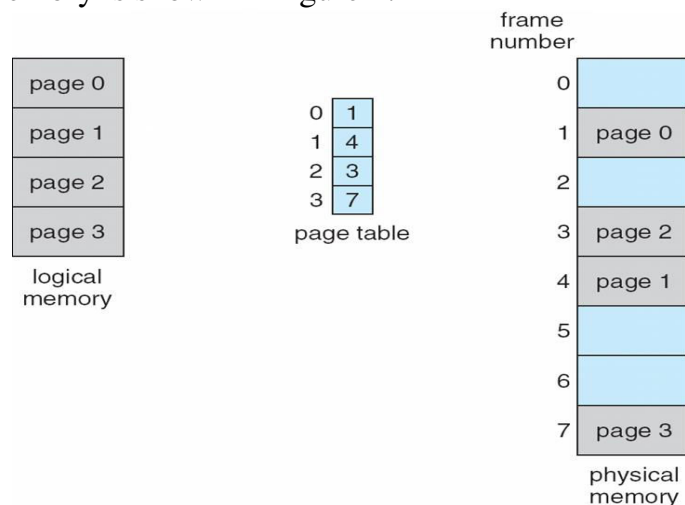
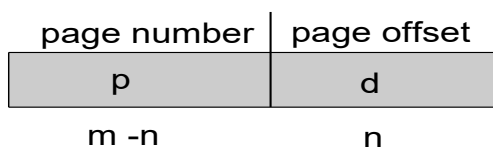

Figure 2: Paging model of logical and physical memory.

- The page size (like the frame size) is defined by the hardware.
- The size of a page is typically a power of 2, varying between 512 bytes and 16 MB per page, depending on the computer architecture.
- The selection of a power of 2 as a page size makes the translation of a logical address into a page number and page offset.
- If the size of logical address space is  $2^m$  and a page size is  $2^n$  addressing units (bytes or words), then the high-order  $m - n$  bits of a logical address designate the page number, and the  $n$  low-order bits designate the page offset.

Thus, the logical address is as follows:



- When a process requests memory (e.g. when its code is loaded in from disk), free frames are allocated from a free-frame list, and inserted into that process's page table.
- Processes are blocked from accessing anyone else's memory because all of their memory requests are mapped through their page table. There is no way for them to generate an address that maps into any other process's memory space.
- The operating system must keep track of each individual process's page table, updating it whenever the process's pages get moved in and out of memory, and applying the correct page table when processing system calls for a particular process. This all increases the overhead involved when swapping processes in and out of the CPU.

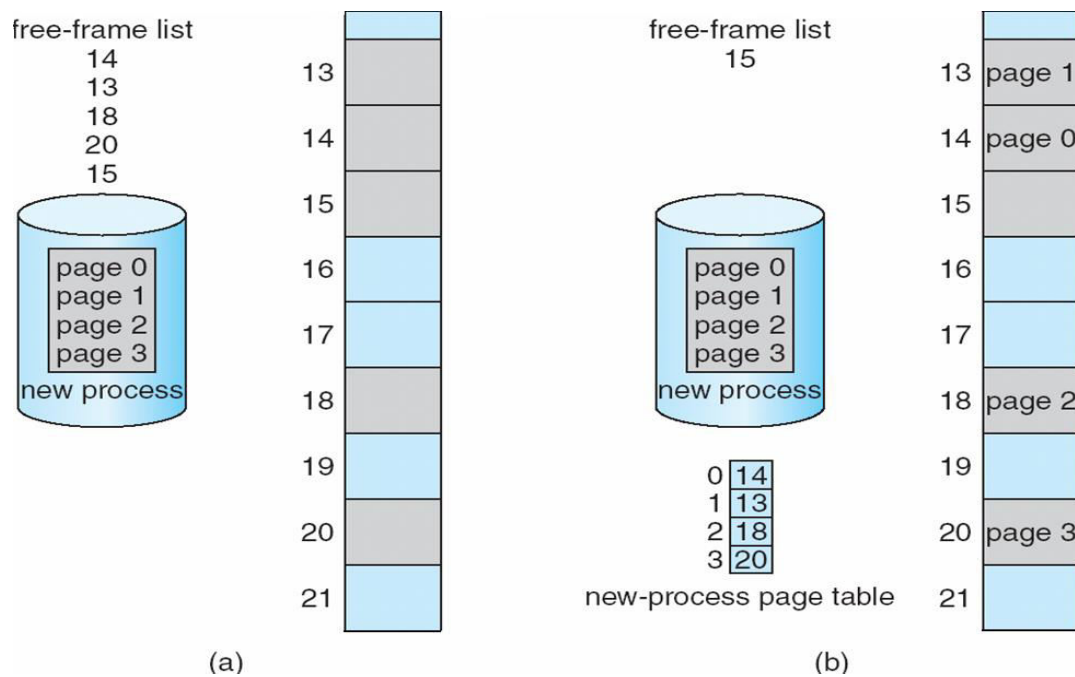

Figure: Free frames (a) before allocation and (b) after allocation.

## Hardware Support

### Translation Look aside Buffer

- A special, small, fast lookup hardware cache, called a translation look-aside buffer (TLB).
- Each entry in the TLB consists of two parts: a key (or tag) and a value.
- When the associative memory is presented with an item, the item is compared with all keys simultaneously. If the item is found, the corresponding value field is returned. The search is fast; the hardware, however, is expensive. Typically, the number of entries in a TLB is small, often numbering between 64 and 1,024.
- The TLB contains only a few of the page-table entries.

### Working:

- When a logical-address is generated by the CPU, its page-number is presented to the TLB.
- If the page-number is found (TLB hit), its frame-number is immediately available and used to access memory
- If page-number is not in TLB (TLB miss), a memory-reference to page table must be made. The obtained frame-number can be used to access memory (Figure 1)

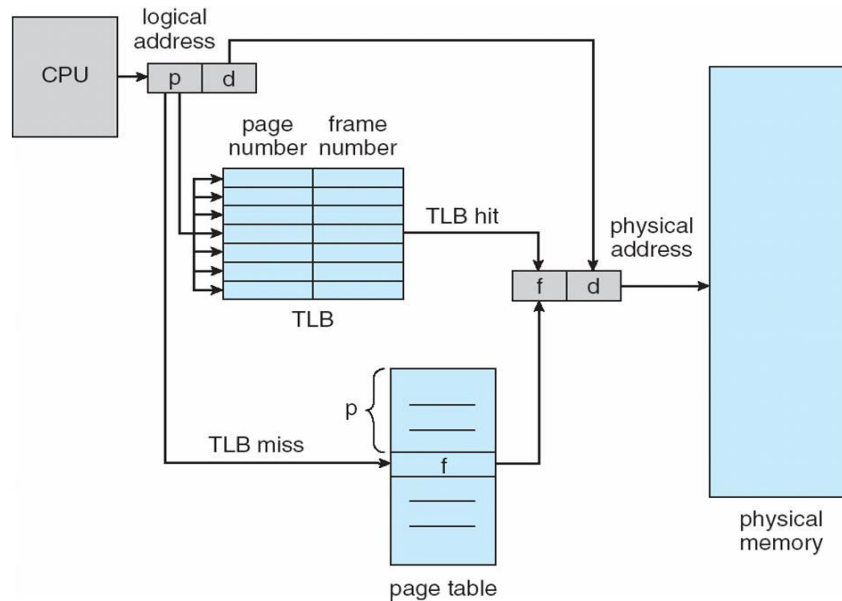

Figure 1: Paging hardware with TLB

- In addition, we add the page-number and frame-number to the TLB, so that they will be found quickly on the next reference.
- If the TLB is already full of entries, the OS must select one for replacement.
- Percentage of times that a particular page-number is found in the TLB is called hit ratio.

Advantage: Search operation is fast.

Disadvantage: Hardware is expensive.

- Some TLBs have wired down entries that can't be removed.
- Some TLBs store ASID (address-space identifier) in each entry of the TLB that uniquely identify each process and provide address space protection for that process.

### Protection

- Memory-protection is achieved by protection-bits for each frame.
- The protection-bits are kept in the page-table.
- One protection-bit can define a page to be read-write or read-only.
- Every reference to memory goes through the page-table to find the correct frame-number.
- Firstly, the physical-address is computed. At the same time, the protection-bit is checked to verify that no writes are being made to a read-only page.
- An attempt to write to a read-only page causes a hardware-trap to the OS (or memory protection violation).

## Valid Invalid Bit

- This bit is attached to each entry in the page-table.
- Valid bit: “valid” indicates that the associated page is in the process’ logical address space, and is thus a legal page
- Invalid bit: “invalid” indicates that the page is not in the process’ logical address space

Illegal addresses are trapped by use of valid-invalid bit.

The OS sets this bit for each page to allow or disallow access to the page.

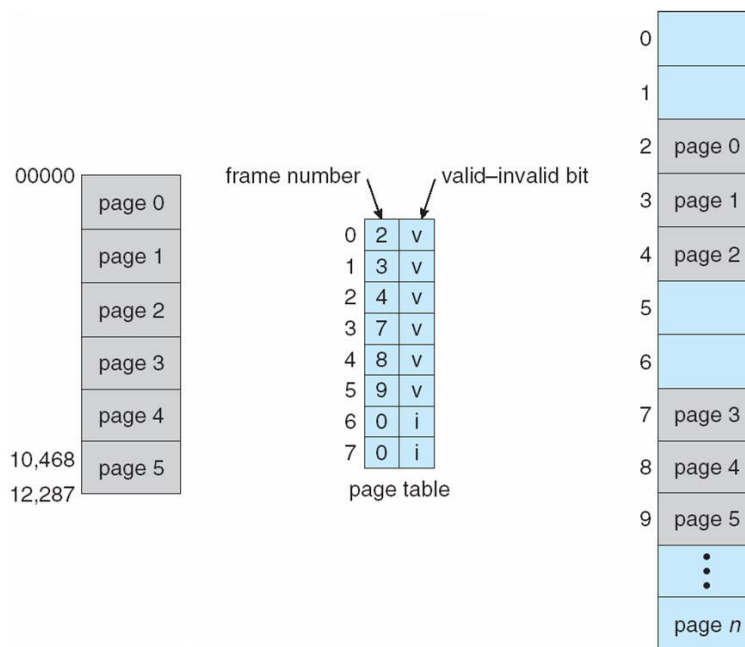

Figure: Valid (v) or invalid (i) bit in a page-table

## Shared Pages

- An advantage of paging is the possibility of sharing common code.
- Re-entrant code (Pure Code) is non-self-modifying code, it never changes during execution.
- Two or more processes can execute the same code at the same time.
- Each process has its own copy of registers and data-storage to hold the data for the process's execution.
- The data for 2 different processes will be different.
- Only one copy of the editor need be kept in physical-memory (Figure 5.12).
- Each user's page-table maps onto the same physical copy of the editor, but data pages are mapped onto different frames.

## Disadvantage:

Systems that use inverted page-tables have difficulty implementing shared-memory.



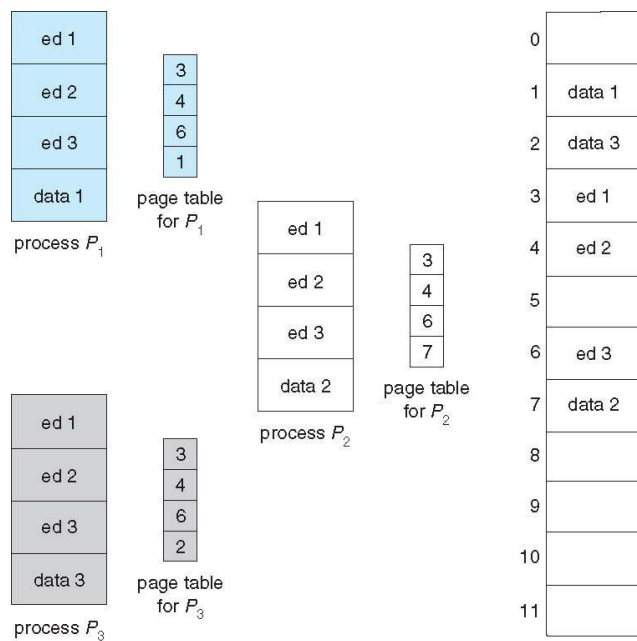

Figure: Sharing of code in a paging environment

## Structure of the Page Table

The most common techniques for structuring the page table:

1. Hierarchical Paging
2. Hashed Page-tables
3. Inverted Page-tables

### 1. Hierarchical Paging

- Problem: Most computers support a large logical-address space ( $2^{32}$  to  $2^{64}$ ). In these systems, the page-table itself becomes excessively large.
- Solution: Divide the page-table into smaller pieces.

### Two Level Paging Algorithm:

- The page-table itself is also paged.
- This is also known as a forward-mapped page-table because address translation works from the outer page-table inwards.

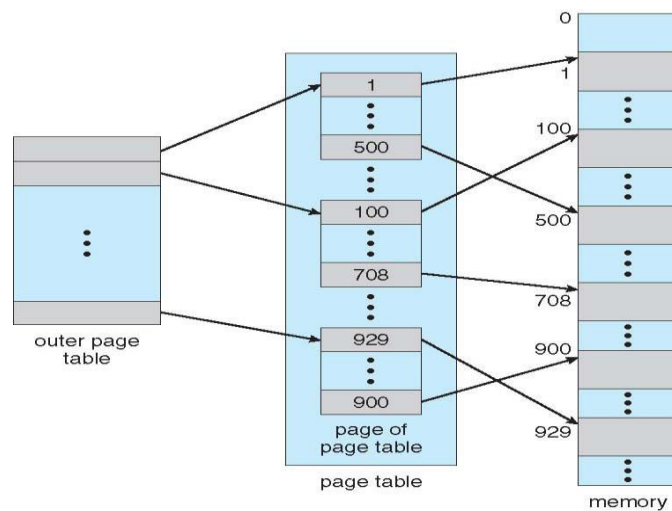

Figure: A two-level page-table scheme

**For example:**

Consider the system with a 32-bit logical-address space and a page-size of 4 KB.

A logical-address is divided into

- 20-bit page-number and
- 12-bit page-offset.

Since the page-table is paged, the page-number is further divided into

- 10-bit page-number and
- 10-bit page-offset.

Thus, a logical-address is as follows:

page number		page offset
$p_1$	$p_2$	$d$
12	10	10

- where  $p_1$  is an index into the outer page table, and  $p_2$  is the displacement within the page of the inner page table

The address-translation method for this architecture is shown in below figure. Because address translation works from the outer page table inward, this scheme is also known as a forward-mapped page table.

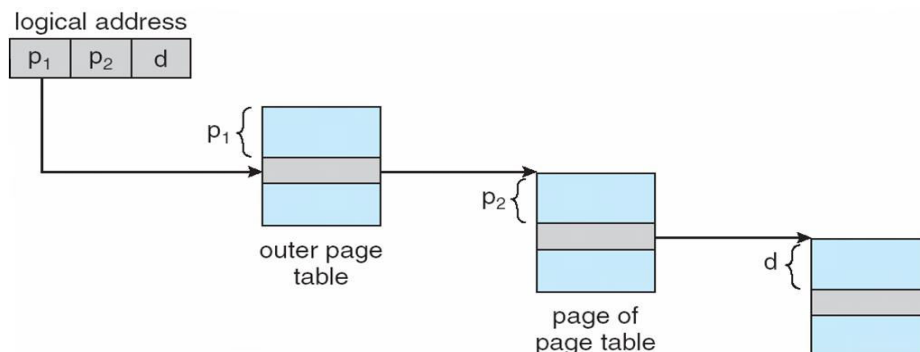

Figure: Address translation for a two-level 32-bit paging architecture

## 2. Hashed Page Tables

- This approach is used for handling address spaces larger than 32 bits.
- The hash-value is the virtual page-number.
- Each entry in the hash-table contains a linked-list of elements that hash to the same location (to handle collisions).
- Each element consists of 3 fields:
  1. Virtual page-number
  2. Value of the mapped page-frame and
  3. Pointer to the next element in the linked-list.

The algorithm works as follows:

- The virtual page-number is hashed into the hash-table.
- The virtual page-number is compared with the first element in the linked-list.
- If there is a match, the corresponding page-frame (field 2) is used to form the desired physical-address.
- If there is no match, subsequent entries in the linked-list are searched for a matching virtual page-number.

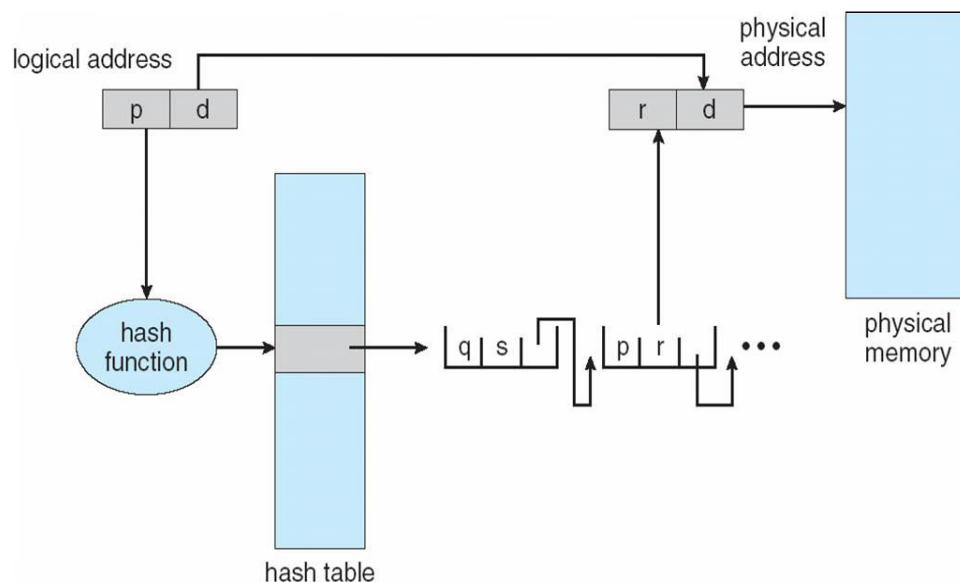

Figure: Hashed page-table

## 3. Inverted Page Tables

- Has one entry for each real page of memory.
- Each entry consists of virtual-address of the page stored in that real memory-location and information about the process that owns the page.
- Each virtual-address consists of a triplet <process-id, page-number, offset>.
- Each inverted page-table entry is a pair <process-id, page-number>

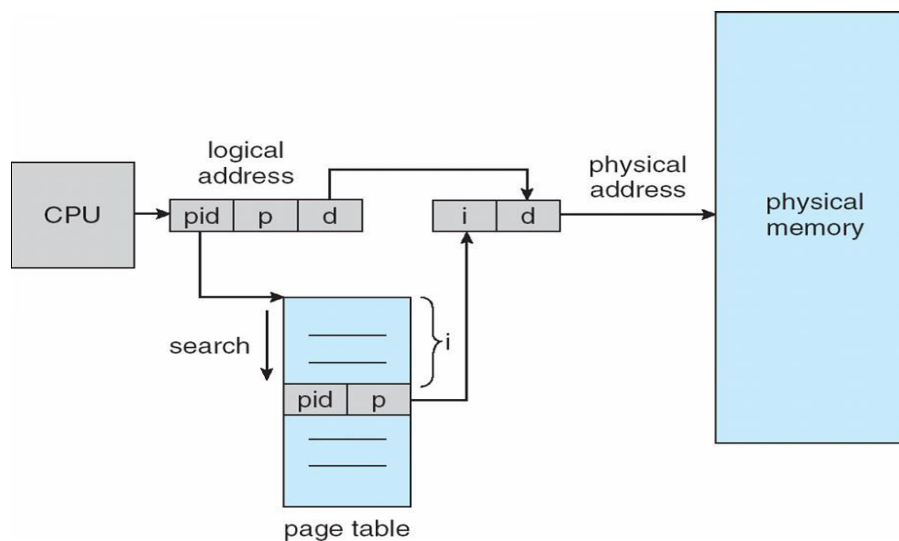

Figure: Inverted page-table

The algorithm works as follows:

1. When a memory-reference occurs, part of the virtual-address, consisting of <process-id, page-number>, is presented to the memory subsystem.
2. The inverted page-table is then searched for a match.
3. If a match is found, at entry i-then the physical-address <i, offset> is generated.
4. If no match is found, then an illegal address access has been attempted.

Advantage:

1. Decreases memory needed to store each page-table

Disadvantages:

1. Increases amount of time needed to search table when a page reference occurs.
2. Difficulty implementing shared-memory

## Segmentation

### Basic Method of Segmentation

- This is a memory-management scheme that supports user-view of memory (Figure 1).
- A logical-address space is a collection of segments.
- Each segment has a name and a length.
- The addresses specify both segment-name and offset within the segment.
- Normally, the user-program is compiled, and the compiler automatically constructs segments reflecting the input program.
- For ex: The code, Global variables, The heap, from which memory is allocated, The stacks used by each thread, The standard C library

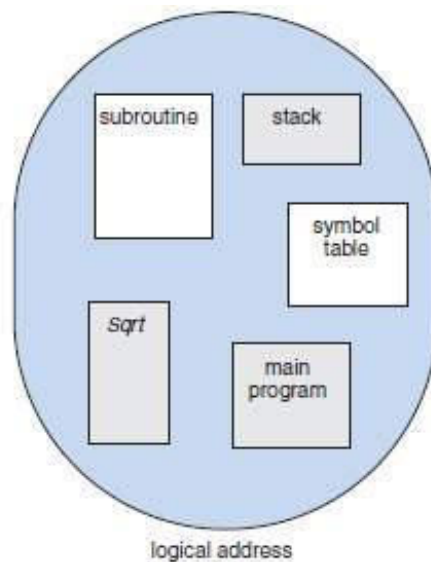

Figure: Programmer's view of a program

### Hardware support for Segmentation

- Segment-table maps 2 dimensional user-defined addresses into one-dimensional physical addresses.
- In the segment-table, each entry has following 2 fields:
  1. Segment-base contains starting physical-address where the segment resides in memory.
  2. Segment-limit specifies the length of the segment (Figure 2).
- A logical-address consists of 2 parts:
  1. Segment-number(s) is used as an index to the segment-table
  2. Offset(d) must be between 0 and the segment-limit.
- If offset is not between 0 & segment-limit, then we trap to the OS(logical-addressing attempt beyond end of segment).
- If offset is legal, then it is added to the segment-base to produce the physical-memory address.

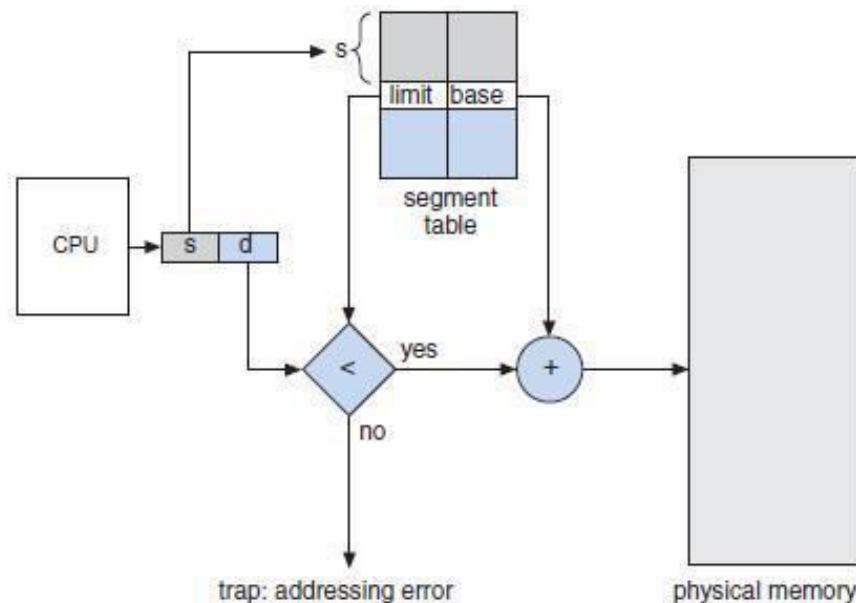

Figure: Segmentation hardware

# QUESTION BANK

## DEADLOCKS

1. What are deadlocks? What are its characteristics? Explain the necessary conditions for its occurrence.
2. Explain the process of recovery from deadlock.
3. Describe RAG:
  - i) With deadlock
  - ii) With a cycle but no deadlock
4. What is Resource Allocation Graph (RAG)? Explain how RAG is very useful in describing deadly embrace (dead lock ) by considering your own example.
5. With the help of a system model, explain a deadlock and explain the necessary conditions that must hold simultaneously in a system for a deadlock to occur.
6. Explain how deadlock can be prevented by considering four necessary conditions cannot hold.
7. Using Banker's algorithm determines whether the system is in a safe state.
8. How is a system recovered from deadlock? Explain the different methods used to recover from deadlock.
9. Explain deadlock detection with algorithm and example
10. Define the terms: safe state and safe sequence. Give an algorithm to find whether or not a system is in a safe state.

## MEMORY MANAGEMENT

1. Explain the multistep processing of a user program with a neat block diagram.
2. Distinguish between internal and external fragmentation.
3. Explain segmentation with an example.
4. Explain with a diagram, how TLB is used to solve the problem of simple paging scheme.
5. With a supporting paging hardware, explain in detail concept of paging with an example for a 32-byte memory with 4-type pages with a process being 16-bytes. How many bits are reserved for page number and page offset in the logical address. Suppose the logical address is 5, calculate the corresponding physical address, after populating memory and page table.
6. What are the draw backs of contiguous memory allocation?
7. Consider a paging system with the page table stored in memory.
  - i. if a memory reference takes 200 nano seconds, how long does a paged memory reference take?
  - ii. if we add associative register and 75 percentage of all page table references are found in the associative registers, what is the effective memory access time? (Assume that finding a page table entry in the associative memory/registers takes

---

zero time, if the entry is found).

8. Distinguish between:
  - i. Logical address space and physical address space.
  - ii. Internal fragmentation and external fragmentation.
  - iii. Paging and segmentation.
9. Explain with the help of supporting hardware diagram how the TLB improves the performance of a demand paging system.
10. Explain the concept of forward mapped page table.
11. What is fragmentation? Explain two types of memory fragmentation
12. What is swapping? Explain in detail.
13. What do you mean by address binding? Explain with the necessary steps, the binding of instructions and data to memory addresses.

## University Questions

June / July 2018

1. Consider the following snapshot of a system

	Allocation			Max			Available		
	A	B	C	A	B	C	A	B	C
P <sub>0</sub>	0	0	2	0	0	4	1	0	2
P <sub>1</sub>	1	0	0	2	0	1			
P <sub>2</sub>	1	3	5	1	3	7			
P <sub>3</sub>	6	3	2	8	4	2			
P <sub>4</sub>	1	4	3	1	5	7			

2. Find the need matrix and calculate safe sequence using Banker's algorithm. Mention the above system is safe or not safe. (08 Marks)
3. What are the necessary conditions for deadlock? Explain different methods to recover from deadlock. (08 Marks)
4. What is paging? Explain paging hardware with translation look-aside buffer. (06 Marks)
5. Explain the structure of page table with respect to hierarchical paging. (06 Marks)
6. Given the 5 memory partitions 100 KB, 500 KB, 200 KB, 300 KB and 600 KB, how each of the first fit, best fit and worst fit algorithms place processes of 212 KB, 417 KB, 112KB and 426KB size. Which algorithm makes efficient use of memory? (04 Marks)

Dec. 2018 / Jan 2019

1. Define deadlock. Write short notes on 4 necessary conditions that arise deadlocks.
2. Assume that there are 5 processes P<sub>0</sub> through P<sub>4</sub> and 4 types of resources. At time T<sub>0</sub> we have the following state :

Process	Allocation				Max				Available			
	A	B	C	D	A	B	C	D	A	B	C	D
P <sub>0</sub>	0	0	1	2	0	0	1	2	1	5	2	0
P <sub>1</sub>	1	0	0	0	1	7	5	0				
P <sub>2</sub>	1	3	5	4	2	3	5	6				
P <sub>3</sub>	0	6	3	2	0	6	5	2				
P <sub>4</sub>	0	0	1	4	0	6	5	6				

3. Apply Banker's algorithm to answer the following :
  - i) What is the content of need matrix?
  - ii) Is the system in a safe state?
  - iii) If a request from a process P<sub>1</sub>(0, 4, 2, 0) arrives, can it be granted?
4. Write short notes on :
  - i) External and internal fragmentation
  - ii) Dynamic loading and linking.
5. Analyze the problem in simple paging technique and show how TLB is used to solve the problem.



1. Determine whether the following system is in safe state by using Banker's algorithm.

Process	Allocation			Maximum			Available		
	A	B	C	A	B	C	A	B	C
P <sub>0</sub>	0	1	0	7	5	3	3	3	2
P <sub>1</sub>	2	0	0	3	2	2			
P <sub>2</sub>	3	0	2	9	0	2			
P <sub>3</sub>	2	1	1	2	2	2			
P <sub>4</sub>	0	0	0	4	3	3			

- If a request for P<sub>1</sub> arrives for (1 0 2), can the request be granted immediately? (09 Marks)
2. Discuss the various approaches used for deadlock recovery. (07 Marks)
3. Illustrate with example, the internal and external fragmentation problem encountered in continuous memory allocation. (07 Marks)
4. Explain the structure of page table. (09 Marks)